

راهنمای فارسی نصب سریع Oxín Drive

# ABO-QP1000



از اینکه محصول ABO-QP1000 ساخت شرکت اکسین را انتخاب کرده اید ، از شما سپاسگزاریم.

**\* بازرسی قبل از نصب**

- بدنه بیرونی درایو به لحاظ خراشیدگی یا آسیب دیدگی بخاطر حمل اشتباه بررسی شود.
- برچسب درایو جهت تطابق درایو ارسال شده با مدل درخواستی بررسی شود.

**\* نکات ایمنی هنگام نصب درایو ( مهم )**

- ✓ بدنه اینورتر مستقیماً به ارت وصل شود.
- ✓ از نصب اینورتر در محیط های قابل اشتعال خودداری شود.
- ✓ از نصب اینورتر با توان پایین تر از توان موتور خودداری شود.
- ✓ قبل از اتصال برق به ورودی اینورتر، از نوع ورودی (سه فاز یا تکفاز) اطمینان حاصل شود.
- ✓ اینورتر را داخل تابلو برق در جایی نصب نمایید که ذرات گرد و غبار و مواد شیمیایی و رطوبت به داخل آن نفوذ نکند.
- ✓ تابلوی اینورتر حتماً مجهز به فن خنک کننده و خروجی هوا باشد.
- ✓ دستگاه را به صورت عمودی و در محل ثابت و بدون لرزش نصب نمایید.
- ✓ دستگاه به گونه ای که از دو طرف پنج سانتی متر و از بالا و پایین حداقل دو سانتی متر فضای آزاد جهت گردش هوا داشته باشد، نصب گردد.
- ✓ دمای کاری اینورتر (۴۰/۱۰-) درجه سانتیگراد میباشد. در صورت افزایش دما به بیش از ۴۰ درجه سانتی گراد جریان نامی اینورتر کاهش میابد.
- ✓ جهت اتصال برق شبکه به ورودی درایو از فیوز مناسب با اینورتر استفاده گردد.
- ✓ اتصال سیم های موتور به اینورتر می بایست مستقیماً صورت پذیرد و از قراردادن هرگونه کلید، کنتاکتور، بانک خازنی، محافظ نوسانات و ... بین موتور و ترمینال های خروجی اینورتر اکیدا خودداری فرمایید.
- ✓ فاصله مجاز بین موتور و اینورتر ۵۰ متر میباشد. برای فواصل طولانی تر باید چوک خروجی مخصوص نیز در خروجی اینورتر نصب گردد.
- ✓ مابقی ترمینالها، ترمینال های فرمان است که هیچ گونه ولتاژی به آن متصل نمیشود.

توجه :

**مصرف کننده محترم، در صورت بروز آسیب به درایو به دلیل عدم رعایت نکات ایمنی ذکر شده ، گارانتی دستگاه لغو میگردد.**

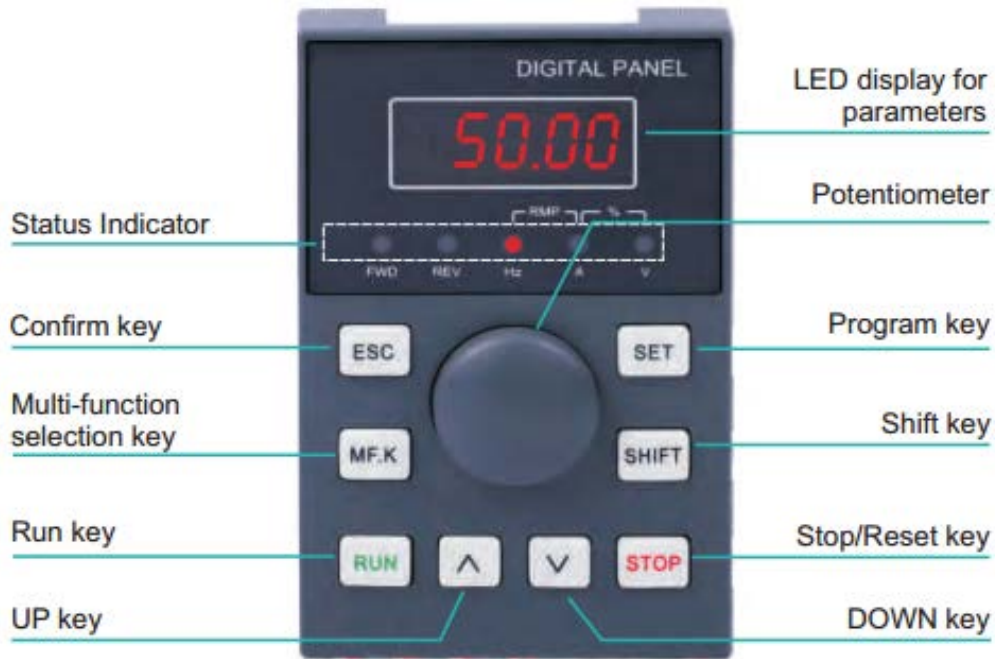

### \* توضیحات چراغ های وضعیت روی صفحه کلید

شرح	نام	نشان
1. دسترسی به گروه پارامترها (منو) 2. تایید تنظیمات پارامتر 3. تایید عملکرد کلید MF.K	کلید اینتر	
1. برگشت به مرحله قبل 2. لغو تنظیمات در حال انجام	کلید اسکپ	
افزایش مقادیر : پارامتر ، فرکانس و ...	کلید آپ (بالا)	
کاهش مقادیر : پارامتر ، فرکانس و ...	کلید دان (پایین)	
1. انتخاب اعداد/مقدار پارامترها 2. تغییر وضعیت از حالت نمایش خطا به نمایش مقدار پارامتر	کلید شیفت	
شروع به کار (استارت)	کلید ران (اجرا)	

## \*سیم بندی

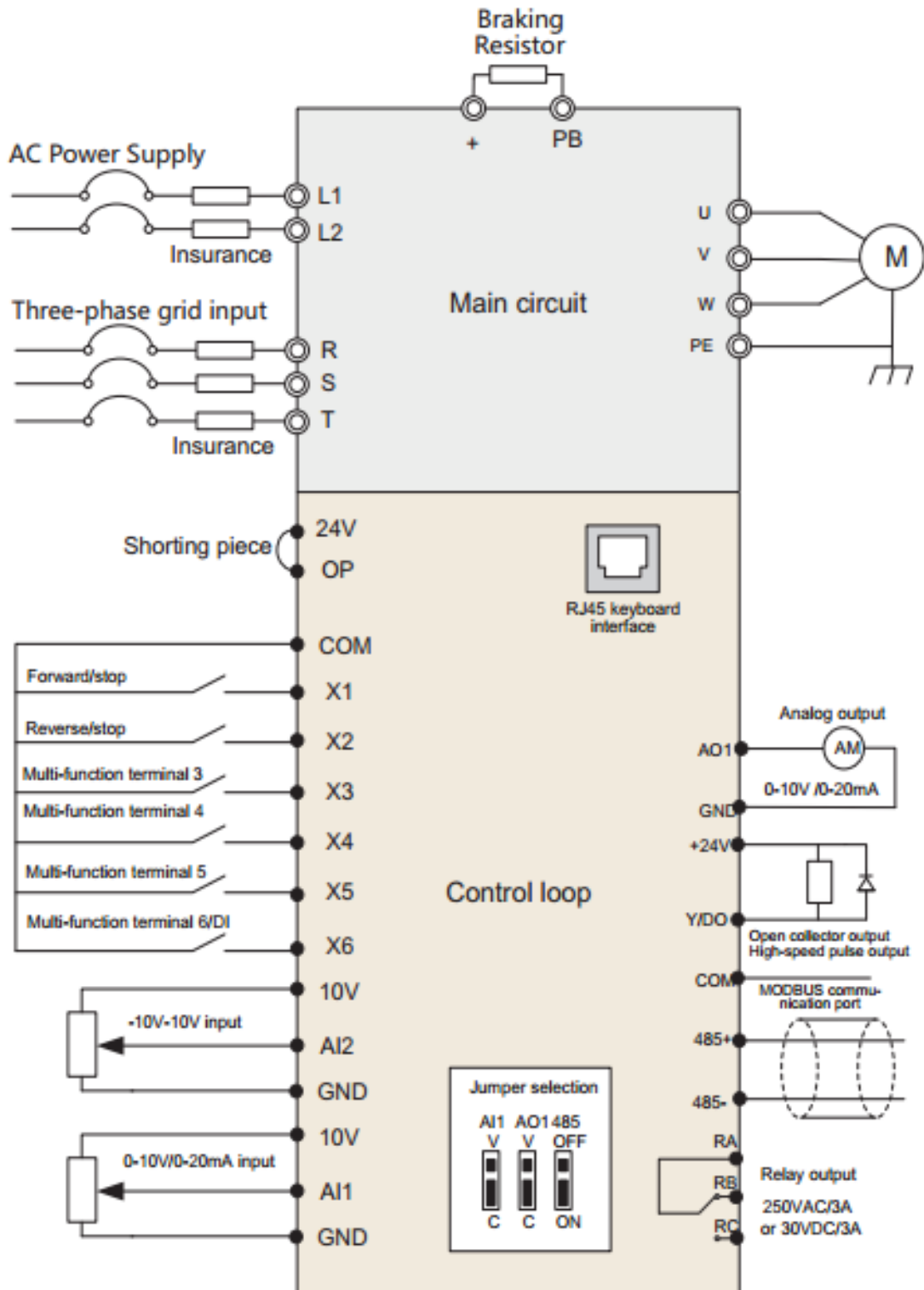

## : P0

توضیحات	مقدار پیش فرض	پارامتر
0: Speed sensorless vector control (SVC) 1: With speed sensor vector control (FVCI) 2: V/F control	2	P0.01 (مد کنترلی)
0: استارت از طریق کی پد (کنترل پنل) 1: استارت از طریق ترمینال 2: استارت از طریق پروتکل‌های ارتباطی	0	P0.02 (مد استارت)
0: Digital setting (no memory when power off) 1: Digital setting (power-down memory) 2: AI1 3: AI2 4: Panel potentiometer 5: Pulse setting (X6) 6: Multi-segment instruction 7: Simple PLC 8: PID 9: Communication given	4	P0.03 (تنظیمات مد فرکانس)
حد فرکانس خروجی Upper limit FREQ ~500.00Hz	50.00Hz	P0.10 (محدوده فرکانس خروجی)
(حد پایین فرکانس پارامتر) P0-10 ~ P0-14 (حد بالای فرکانس)	50.00Hz	P0.12 (حد بالای فرکانس)
حد بالای فرکانس ~0.00Hz	0.00Hz	P0.14 (حد پایین فرکانس)
مدت زمان افزایش شتاب ، جهت رسیدن به دور نامی از لحظه استارت کردن موتور ( 0s ~ 65000s )	Model dependent	P0.17 (Acc Time)
مدت زمان کاهش شتاب ، از لحظه اعمال فرمان توقف به موتور تا رسیدن به فرکانس صفر ( 0s ~ 65000s )	Model dependent	P0.18 (Dec Time)
0.01s : 0 0.1s : 1 1s : 2	1	P0.19 (زمان پاسخ Acc/Dec)

0: بدون حافظه 1: حافظه	0	P0.23 (تنظیم فرکانس حافظه)
---------------------------	---	----------------------------------

### P1 پارامتر های موتوری :

توضیحات	پیش فرض	پارامتر
توان نامی بر اساس پلاک موتور		P1.01
ولتاژ نامی بر اساس پلاک موتور		P1.02
جریان نامی بر اساس پلاک موتور		P1.03
فرکانس نامی بر اساس پلاک موتور		P1.04
دور نامی بر اساس پلاک موتور		P1.05

### Torque boost:

توضیحات	پیش فرض	پارامتر
0.0%: (without torque boost) 0.1%~30.0%		P3.01

### P4 (ورودیهای دیجیتال چند منظوره) :

توضیحات	پیش فرض	پارامتر
عملکرد ترمینال چندکاره X1 (0 – 49)	0	P4.00
عملکرد ترمینال چندکاره X2 (0 – 49)	4	P4.01
عملکرد ترمینال چندکاره X3 (0 – 49)	9	P4.02
عملکرد ترمینال چندکاره X4 (0 – 49)	12	P4.03
عملکرد ترمینال چندکاره X5 (0 – 49)	13	P4.04
عملکرد ترمینال چندکاره X6 (0 – 49)	0	P4.05

P4-00	Function of terminal X1	0: No function 1: Forward running FWD 2: Run REV in reverse 3: Three-wire running control 4: Forward jog (FJOG) 5: Reverse Jog (RJOG) 6: Terminal UP	0	★
P4-01	Function of terminal X2	7: Terminal DOWN 8: Free parking 9: Fault reset (RESET) 10: Run pause 11: External fault normally open input 12: Multi-segment command terminal 1 13: Multi-segment command terminal 2	4	★
P4-02	Function of terminal X3	14: Multi-segment command terminal 3 15: Multi-segment command terminal 4 16: Acceleration and deceleration time selection terminal 1 17: Acceleration and deceleration time selection terminal 2	9	★
P4-03	Function of terminal X4	18: Frequency command switching 19: UP/DOWN setting clear 20: Control command switching terminal 1 21: Acceleration and deceleration prohibition	12	★
P4-04	Function of terminal X5	22: PID pause 23: Simple PLC state reset 24: Swing frequency pause 25: Counter input 26: Counter reset 27: Length count input 28: Length reset	13	★
P4-05	Function of terminal X6	29: Torque control prohibited 30: Pulse frequency input (only valid for X6) 32: Immediate DC braking 33: External fault normally closed input 34: Frequency modification enable	0	★

		35: PID action direction is reversed 36: External parking terminal 1 37: Control command switching terminal 2 38: PID integral pause 39: Switch between main frequency and preset frequency 40: Switch between auxiliary frequency and preset frequency 41: Motor terminal selection function 42: reserved 43: PID parameter switching 44: User-defined fault 1 45: User-defined fault 2 46: Speed control/torque control switching 47: Emergency stop 48: External parking terminal 2 49: Deceleration DC braking		
--	--	--	--	--

### P4 پارامتر مد راه اندازی :

توضیحات	پیش فرض	پارامتر
0: مد ۱ راه اندازی دو سیم 1: مد ۲ راه اندازی دوسیم 2: مد ۱ راه اندازی سه سیم 3: مد ۲ راه اندازی سه سیم	0	P4.11

### P8 تنظیمات عملکرد JOG :

توضیحات	پیش فرض	پارامتر
0: 0.00Hz~upper limit FREQ	2.00Hz	P8.00 (Jog FREQ)
1: 0.0s~6500.0s	20.0s	P8.01 (Jog Accel time)
2: 0.0s~6500.0s	20.0s	P8.02 (Jog Decel time)



## P8 پارامتر wake up &amp; sleep :

توضیحات	پیش فرض	پارامتر
Sleep frequency (P8-51)~Maximum frequency (P0-10)	0.00Hz	P8.49 (wake up frequency)
0.0s~6500.0s	0.0s	P8.50 (Wake up delay time)
0.00Hz~Wake up frequency (P8-49)	0.00Hz	P8.51 (Sleep frequency)
0.0s~6500.0s	0.0s	P8.52 (sleep delay time)

## PP تنظیمات کارخانه :

توضیحات	پیش فرض	پارامتر
0: No operation 01: Restore factory parameters, excluding motor parameters 02: Clear record information 04: Backup user's current parameters 05: Restore user backup parameters	0	PP.01 (Parameter initialization)

\* برخی از خطاهای رایج :

Fault Name	Operating Panel Display	Cause	Possible Solution
Overcurrent during acceleration	<b>Err02</b>	Ground fault or short circuit exists in the output circuit.	❖ Check whether short-circuit occurs on the motor, motor cable or contactor.
		Control mode is SVC or FVC but motor auto-tuning is not performed.	❖ Set motor parameters according to motor nameplate and perform motor autotuning.
		Acceleration time is too short.	❖ Increase acceleration time.
		The overcurrent stall prevention parameters are set improperly.	❖ Ensure that current limit is enabled (P3-19=1). ❖ The setting of current limit level (P3-18) is too large. Adjust it between 120% and 150%. ❖ The setting of current limit gain (P3-20) is too small. Adjust it between 20 and 40.
		Customized torque boost or V/F curve is not appropriate.	❖ Adjust the customized torque boost or V/F curve.
		The spinning motor is started.	❖ Enable the flying start function or start the motor after it stops.
		The AC drive suffers external interference.	❖ View historical fault records. If the current value is far from the overcurrent level, find interference source. If external interference does not exist, it is the driver board or hall device problem.
Overcurrent during deceleration	<b>Err03</b>	Ground fault or short circuit exists in the output circuit.	❖ Check whether short-circuit occurs on the motor, motor cable or contactor.
		Control mode is SVC or FVC but motor auto-tuning is not performed.	❖ Set motor parameters according to motor nameplate and perform motor auto-tuning.

Fault Name	Operating Panel Display	Cause	Possible Solution
Overcurrent during deceleration	<b>Err03</b>	Deceleration time is too short.	<ul style="list-style-type: none"> <li>◇ Increase deceleration time.</li> </ul>
		The overcurrent stall prevention parameters are set improperly.	<ul style="list-style-type: none"> <li>◇ Ensure that current limit is enabled (P3-19=1).</li> <li>◇ The setting of current limit level (P3-18) is too large. Adjust it between 120% and 150%.</li> <li>◇ The setting of current limit gain (P3-20) is too small. Adjust it between 20 and 40.</li> </ul>
		Braking unit and braking resistor are not installed.	<ul style="list-style-type: none"> <li>◇ Install braking unit and braking resistor.</li> </ul>
		The AC drive suffers external interference.	<ul style="list-style-type: none"> <li>◇ View historical fault records. If the current value is far from the overcurrent level, find interference source. If external interference does not exist, it is the driver board or hall device problem.</li> </ul>
Overcurrent during deceleration	<b>Err04</b>	Ground fault or short circuit exists in the output circuit.	<ul style="list-style-type: none"> <li>◇ Check whether short-circuit occurs on the motor, motor cable or contactor.</li> </ul>
		Control mode is SVC or FVC but motor auto-tuning is not performed.	<ul style="list-style-type: none"> <li>◇ Set motor parameters according to motor nameplate and perform motor auto-tuning.</li> </ul>
		The overcurrent stall prevention parameters are set improperly.	<ul style="list-style-type: none"> <li>◇ Ensure that current limit is enabled (P3-19=1).</li> <li>◇ The setting of current limit level (P3-18) is too large. Adjust it between 120% and 150%.</li> <li>◇ The setting of current limit gain (P3-20) is too small. Adjust it between 20 and 40.</li> </ul>
		The AC drive power class is small.	<ul style="list-style-type: none"> <li>◇ If output current exceeds rated motor current or rated output current of the AC drive during stable running, replace a drive of larger power class.</li> </ul>
		The AC drive suffers external interference.	<ul style="list-style-type: none"> <li>◇ View historical fault records. If the current value is far from the overcurrent level, find interference source. If external interference does not exist, it is the driver board or hall device problem.</li> </ul>

Fault Name	Operating Panel Display	Cause	Possible Solution
Overvoltage during acceleration	Err05	Input voltage is too high.	✦ Adjust input voltage to normal range.
		An external force drives motor during acceleration.	✦ Cancel the external force or install a braking resistor.
		The overvoltage stall prevention parameters are set improperly.	<ul style="list-style-type: none"> <li>✦ Ensure that the voltage limit function is enabled (P3-23=1).</li> <li>✦ The setting of voltage limit (P3-22) is too large. Adjust it between 770 V and 700 V.</li> <li>✦ The setting of frequency gain for voltage limit (P3-24) is too small. Adjust it between 30 and 50.</li> </ul>
		Braking unit and braking resistor are not installed.	✦ Install braking unit and braking resistor.
		Acceleration time is too short.	✦ Increase acceleration time.
Overvoltage during deceleration	Err06	The overvoltage stall prevention parameters are set improperly.	<ul style="list-style-type: none"> <li>✦ Ensure that the voltage limit function is enabled (P3-23=1).</li> <li>✦ The setting of voltage limit (P3-22) is too large. Adjust it between 770V and 700V.</li> <li>✦ The setting of frequency gain for voltage limit (P3-24) is too small. Adjust it between 30 and 50.</li> </ul>
		An external force drives motor during deceleration.	✦ Cancel the external force or install a braking resistor.
		Deceleration time is too short.	✦ Increase deceleration time.
		Braking unit and braking resistor are not installed.	✦ Install braking unit and braking resistor.
Overvoltage at constant speed	Err07	The overvoltage stall prevention parameters are set improperly.	<ul style="list-style-type: none"> <li>✦ Ensure that the voltage limit function is enabled (P3-23=1).</li> <li>✦ The setting of voltage limit (P3-22) is too large. Adjust it between 770 V and 700 V.</li> <li>✦ The setting of frequency gain for voltage limit (P3-24) is too small. Adjust it between 30 and 50.</li> <li>✦ The setting of frequency rise threshold during voltage limit (P3-26) is too small. Adjust it between 5 Hz and 20 Hz.</li> </ul>

Fault Name	Operating Panel Display	Cause	Possible Solution
Overvoltage at constant speed	Err07	An external force drives motor during running.	✧ Cancel the external force or install a braking resistor.
Control power fault	Err08	The input voltage exceeds the setting range.	✧ Adjust the input voltage to be within the setting range.
Undervoltage	Err09	Instantaneous power failure occurs	✧ Enable the power dip ride through function (P9-59≠0).
		The AC drive's input voltage is not within the permissible range.	✧ Adjust the voltage to normal range.
		The bus voltage is abnormal.	✧ Contact the agent or Inovance.
		The rectifier bridge, the buffer resistor, the driver board or the control board are abnormal.	✧ Contact the agent or Inovance.
AC drive overload	Err10	Load is too heavy or locked-rotor occurs on motor.	✧ Reduce load or check motor and mechanical conditions.
		The AC drive power class is small.	✧ Replace a drive of larger power class.
Motor overload	Err11	P9-01 (Motor overload protection gain) is set improperly.	✧ Set P9-01 correctly.
		Load is too heavy or locked-rotor occurs on motor.	✧ Reduce load or check motor and mechanical conditions.
Input phase loss	Err12	Input phase loss occurs.	✧ Eliminate faults in external circuitry.
		Driver board, lightning protection board, control board, or rectifier bridge is abnormal.	✧ Contact the agent or Inovance.
Output phase loss	Err13	Motor winding is damaged.	✧ Check resistance between motor wires.
		The cable connecting the AC drive and the motor is abnormal.	✧ Check for wiring errors and ensure the output cable is connected properly.
		The AC drive's three-phase outputs are unbalanced when the motor is running.	✧ Check whether the motor three-phase winding is normal.
		The driver board or the IGBT is abnormal.	✧ Contact the agent or Inovance.

Fault Name	Operating Panel Display	Cause	Possible Solution
IGBT overheat	Err 14	The ambient temperature is too high.	✧ Lower the ambient temperature.
		The ventilation is clogged.	✧ Clean the ventilation.
		The fan is damaged.	✧ Replace the cooling fan.
		Thermally sensitive resistor of IGBT is damaged.	✧ Replace the damaged thermally sensitive resistor.
		The AC Drive IGBT is damaged.	✧ Replace the AC Drive IGBT.
External fault	Err 15	External fault signal is input through DI.	✧ Confirm that the mechanical condition allows restart (P8-18) and reset the operation.
		External fault signal is input through virtual I/O.	✧ Confirm that the virtual I/O parameters in group A1 are set correctly and reset the operation.
Communication fault	Err 16	Host controller is in abnormal state.	✧ Check the cable of host controller.
		Communication cable is abnormal.	✧ Check the communication cables.
		The serial port communication protocol (P0-28) of extension communication card is set improperly.	✧ Set P0-28 of extension communication card correctly.
		Communication parameters in group Fd are set improperly.	✧ Set communication parameters in group Fd properly.
		After all the preceding checkings are done but the fault still exists, restore the default settings.	
Contactor fault	Err 17	Driver board and power supply are abnormal.	✧ Replace driver board or power supply board.
		Contactor is abnormal.	✧ Replace contactor.
		The lightning protection board is abnormal.	✧ Replace the lightning protection board.
Current detection fault	Err 18	The hall is abnormal.	✧ Replace the hall element.
		The driver board is abnormal.	✧ Replace the driver board.

Fault Name	Operating Panel Display	Cause	Possible Solution
Motor auto-tuning fault	Err19	Motor parameters are not set according to nameplate.	✦ Set motor parameters correctly according to nameplate.
		Motor auto-tuning times out.	✦ Check the cable connecting AC drive and motor.
		The encoder is abnormal.	✦ Check whether P1-27 (encoder pulses perrevolution) is set correctly. Check whether signal lines of encoder are connected correctly and securely.
Encoder fault	Err20	Encoder is not matched.	✦ Set the type of encoder correctly.
		Encoder wiring is incorrect.	✦ Check the PG card power supply and phase sequence.
		Encoder is damaged.	✦ Replace encoder.
		PG card is abnormal.	✦ Replace PG card.
EEPROM read-write fault	Err21	The EEPROM chip is damaged.	✦ Replace the main control board.
Short circuit to ground	Err23	Motor is short circuited to the ground.	✦ Replace cable or motor.
Accumulative running time reached	Err26	Accumulative running time reaches the setting value.	✦ Clear the record through parameter initialization.
User-defined Fault 1	Err27	User-defined fault 1 is input through DI.	✦ Reset the operation.
		User-defined fault 1 is input through virtual I/O.	✦ Reset the operation.
User-defined Fault 2	Err28	User-defined fault 2 is input through DI.	✦ Reset the operation.
		User-defined fault 2 is input through virtual I/O.	✦ Reset the operation.
Accumulative power-on time reached	Err29	Accumulative power-on time reaches the setting value.	✦ Clear the record through parameter initialization.
Load loss	Err30	The output current of AC drive is smaller than F9-64 (load loss detection level).	✦ Check whether load is disconnected or the setting of P9-64 and P9-65 (load lost detection time) satisfies actual running condition.

Fault Name	Operating Panel Display	Cause	Possible Solution
PID feedback lost during running Feedback loss	Err31	PID feedback is smaller than the setting value of PA-26 (detection level of PID feedback loss).	✧ Check PID feedback or set PA-26 properly.
Pulse-by-pulse current limit fault	Err40	Load is too heavy or locked-rotor occurs on motor.	✧ Reduce load or check motor and mechanical conditions.
		The AC drive power class is small.	✧ Replace a drive of larger power class.
Motor switchover fault during running Motor winding is damaged.	Err41	Motor switchover through terminal during drive running of the AC drive.	✧ Perform motor switchover after the AC drive stops.
Speed error	Err42	Encoder parameters are set improperly.	✧ Set encoder parameters properly.
		Motor auto-tuning is not performed.	✧ Perform motor auto-tuning.
		P9-69 (detection level of speed error) and P9-70 (detection time of speed error) are set incorrectly.	✧ Set P9-69 and P9-70 correctly based on actual condition.
Motor overspeed Problem	Err43	Encoder parameters are set improperly.	✧ Set encoder parameters properly.
		Motor auto-tuning is not performed.	✧ Perform motor auto-tuning.
		P9-67 (Overspeed detection level) and P9-68 (Overspeed detection time) are set incorrectly.	✧ P9-67 and P9-68 correctly based on actual condition.
Motor overtemperature	Err45	Cable connection of temperature sensor becomes loose	✧ Check cable connection of temperature sensor.
		The motor temperature is too high.	✧ Decrease carrier frequency or take other measures to cool the motor.
Initial position angle identification fault	Err51	AC drive output phase loss	✧ Check whether the motor wiring is correct.
		The AC drive current detection fails or the hall is damaged.	✧ Check the hall.



Fault Name	Operating Panel Display	Cause	Possible Solution
Initial position angle identification fault	Err51	The motor inductance is too large.	✧ Set P9-75 to avoid this fault.
Braking unit overload	Err61	Resistance of braking resistor is too small.	✧ Replace a braking resistor of larger resistance.
Short-circuit of braking circuit	Err62	Braking module is abnormal.	✧ Contact the agent or Inovance.
Counter electromotive force identification exception warning	A 64	Related parameters are set incorrectly.	✧ Set related parameters correctly, the rated frequency and rotation speed in particular.
		P1-20 is set incorrectly.	✧ Check whether P1-20 is set to a too large or too small value.
		Counter electromotive force identification exception during dynamic identification	✧ Check whether the motor has no load during dynamic identification and whether the motor rotates at 40% of the rated rotation speed. If the motor has load and its speed is below 40% of the rated rotation speed, perform identification again after disconnecting the motor from load.
		The motor is demagnetized.	✧ Check whether the motor is demagnetized.
		Counter electromotive force is too large or too small.	✧ If yes, press STOP to reset the warning and the motor continues to run.

### \*ضرورت استفاده از مقاومت ترمز

هنگامی که بار زیادی به موتور وصل و موتور در حال حرکت میباشد چنانچه به اینورتر فرمان توقف دهیم ، بار موتور را میچرخاند یعنی حالت ژنراتوری ایجاد میشود .

از طرف دیگر چون خازن های اینورتر توانایی تحمل ولتاژ اضافی را ندارند و به آنها آسیب میرسد ، مدارات حفاظت اینورتر فعال شده و خروجی قطع میشود و یا به صورت اتوماتیک زمان Dec افزایش یافته تا ولتاژ تولید شده توسط موتور کاهش یابد ، بنابراین مدت زمان زیادی طول میکشد تا بار بایستد و در روند کار دستگاه اختلال ایجاد میشود .

برای جلوگیری از این حالت از یک مقاومت ترمز استفاده میکنیم تا ولتاژ اضافی در آن بصورت گرما تخلیه شود .

\* اینورترهای Oxín Drive مدل ABO-QP1000 رنج 22/30 کیلووات و ما قبل آن ، دارای یونیت چاپر داخلی میباشد.

\*مقاومت ترمز باید به ترمینال های PB و + متصل شود.

### \*جدول مشخصات مقاومت \*

	Model	$\Omega$	W
1	ABO-4T2.2B	$X \geq 100$	300
2	ABO-4T3.7B	$X \geq 100$	450
3	ABO-4T5.5B	$X \geq 80$	500
4	ABO-4T7.5G/11LB	$X \geq 75$	500
5	ABO-4T11G/15LB	$X \geq 30$	800
6	ABO-4T15G/18.5LB	$X \geq 25$	1000
7	ABO-4T18.5G/22LB	$X \geq 16$	1300
8	ABO-4T22G/30LB	$X \geq 16$	1500
9	ABO-4T30G/37L	$X \geq 16$	2000
10	ABO-4T37G/45L	$X \geq 16$	2000
11	ABO-4T45G/55L (Optional)	$X \geq 10$	3000
12	ABO-4T55G/75L (Optional)	$X \geq 5$	3600